

**VIDEO OUT**

Collegare il cavetto a corredo prodotto all'ingresso VIDEO-IN del Posto Esterno Audio 1083/64.  
*Connect the wire provided with the product to the VIDEO-IN port of the audio door unit 1083/64.*  
 Brancher le câble livré avec le produit à l'entrée VIDEO-IN du Poste Externe Audio 1083/64.  
*Conectar el cable entregado con el producto en la entrada VIDEO-IN del Microaltavoz Audio 1083/64.*  
 Das im Lieferumfang des Produkts enthaltene Kabel an den Eingang VIDEO-IN der Audio-Außenstelle 1083/64 anschließen.

**JP**

Jumper non utilizzato, da non togliere.  
*Jumper not used, do not remove.*  
 Cavalier non utilisé, à ne pas enlever.  
*Puente no utilizado, no se debe retirar.*  
 Nicht verwendeter Jumper, darf nicht entfernt werden.

**urmet**

**2**  
voice

**Mod.  
1758**

DS 1758-004A

LBT 20053

**MODULO TELECAMERA  
CAMERA MODULE  
MODULE TELECAMERA  
MÒDULO UNIDAD DE FILMACIÒN  
KAMERA MODUL**

**Sch./Ref. 1758/83**

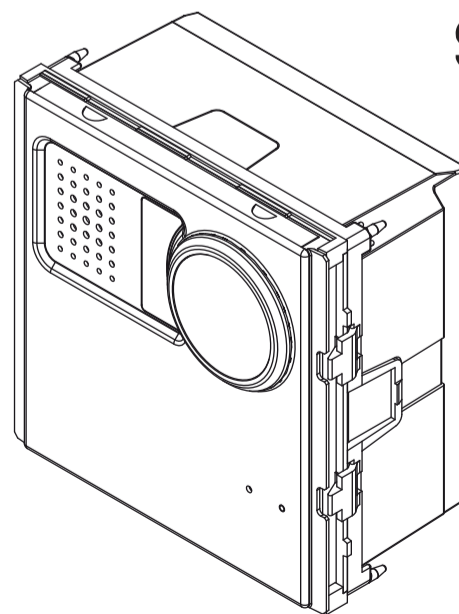

**synthesi**  
steel

DS 1758-004A

**urmet**

LBT 20053

URMET S.p.A.  
10154 TORINO (ITALY)  
VIA BOLOGNA 188/C  
Telef. +39 011.24.00.000 (RIC. AUT.)  
Fax +39 011.24.00.300 - 323

Area tecnica  
servizio clienti +39 011.23.39.810  
<http://www.urmet.com>  
e-mail: [info@urmet.com](mailto:info@urmet.com)

1

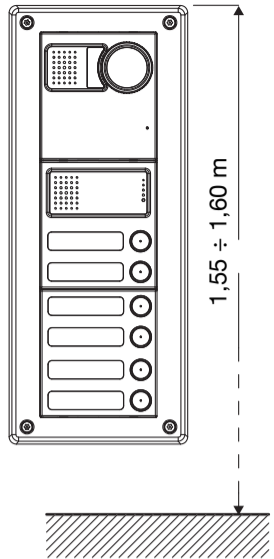

Campo di ripresa verticale  
Vertical shooting field  
Champ de prise de vue vertical  
Campo de adquisición vertical  
Vertikales Aufnahmefeld

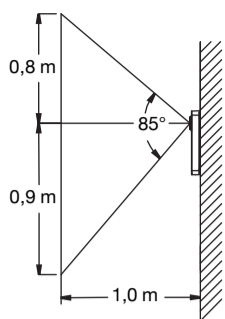

Campo di ripresa orizzontale  
Horizontal shooting field  
Champ de prise de vue horizontal  
Campo de adquisición horizontal  
Horizontales Aufnahmefeld

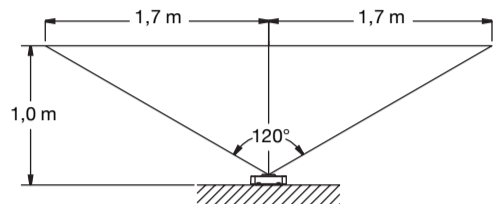

2

Sch./Ref. 1158/41  
Sch./Ref. 1158/42  
Sch./Ref. 1158/43  
Sch./Ref. 1158/44

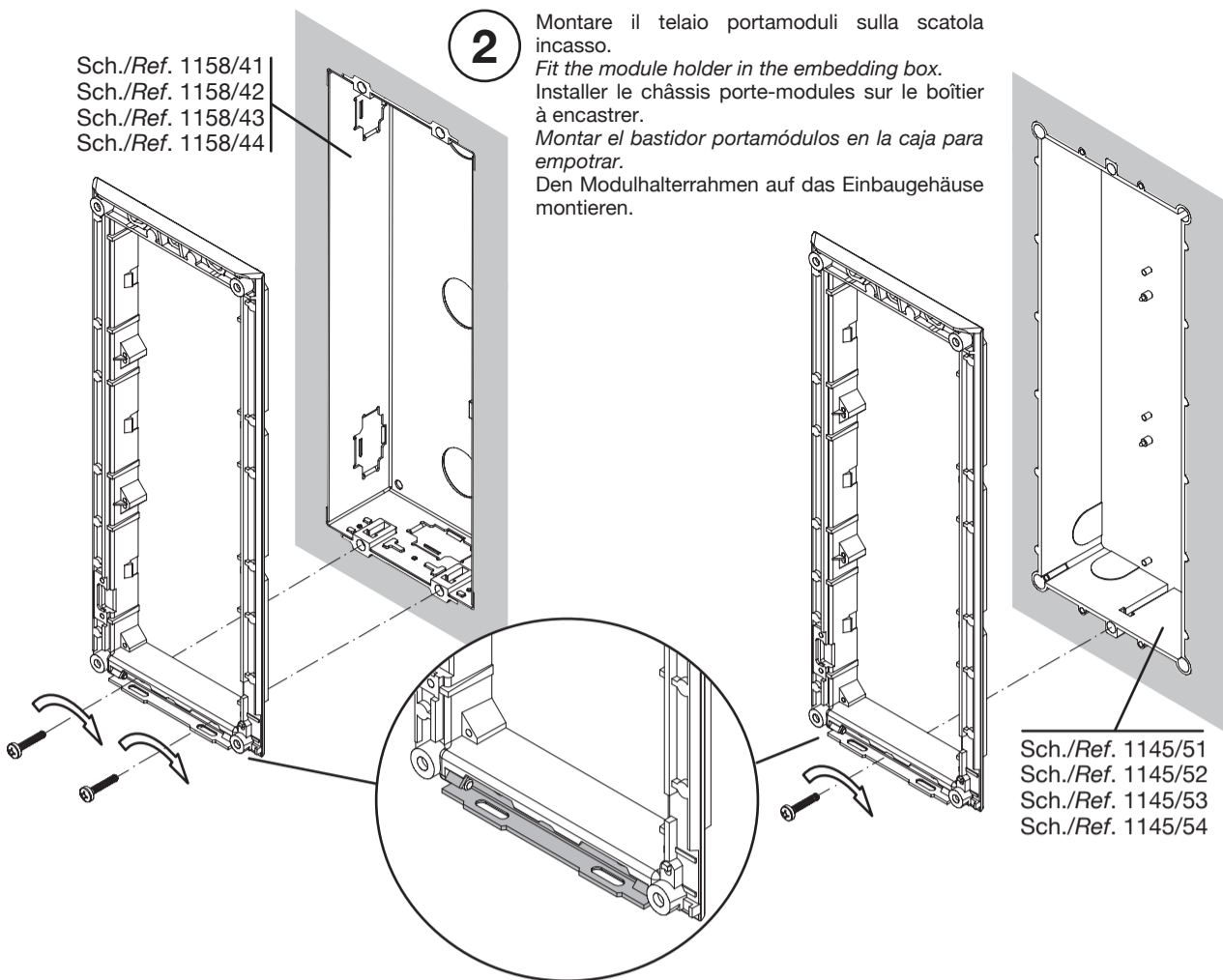

Montare il telaio portamoduli sulla scatola incasso.  
Fit the module holder in the embedding box.  
Installer le châssis porte-modules sur le boîtier à encastrer.  
Montar el bastidor portamódulos en la caja para empotrar.  
Den Modulhalterrahmen auf das Einbaugehäuse montieren.

Sch./Ref. 1145/51  
Sch./Ref. 1145/52  
Sch./Ref. 1145/53  
Sch./Ref. 1145/54

3

Montare i moduli sul telaio.  
Fit the modules on the module holder.  
Installer les modules sur le châssis.  
Montar los módulos en el bastidor.  
Die Module auf den Rahmen montieren.

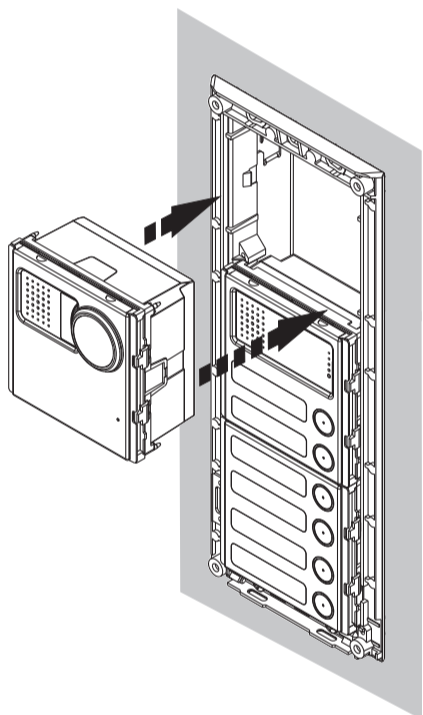

4

Ribaltare il telaio ed effettuare i cablaggi.  
Turn the module holder round and connect wires.  
Basculer le châssis et réaliser les câblages.  
Girar el bastidor y realizar los cableados.  
Den Rahmen umkippen und die Verkabelung durchführen.

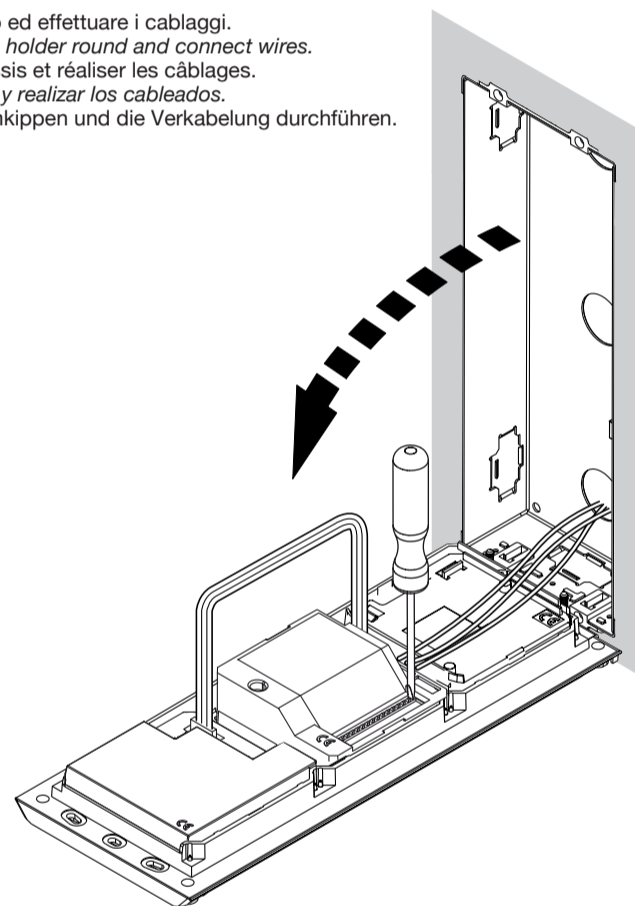

5

Chiudere il telaio.  
Close the module holder.  
Fermer le châssis.  
Cerrar el bastidor.  
Den Rahmen schließen.

Regolare la corretta perpendicolarità della pulsantiera.  
Adjust correct perpendicularity of push-button panel.  
Veiller à la perpendicularité correcte du clavier.  
Regular la correcta perpendicularidad del teclado.  
Die Rechtwinkligkeit des Bedienpultes richtig einstellen.

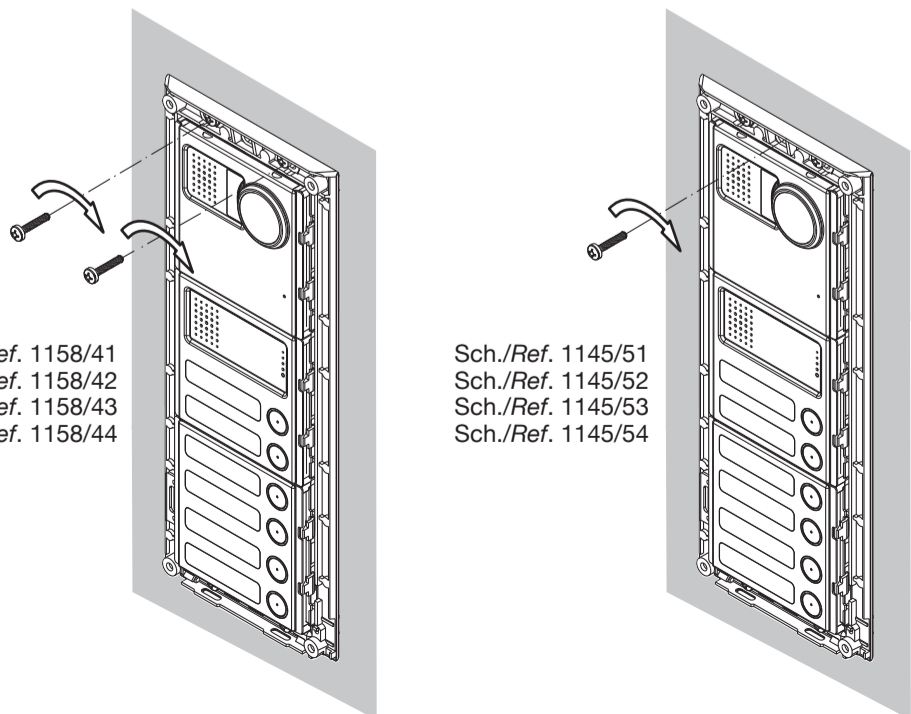

Sch./Ref. 1158/41  
Sch./Ref. 1158/42  
Sch./Ref. 1158/43  
Sch./Ref. 1158/44

Sch./Ref. 1145/51  
Sch./Ref. 1145/52  
Sch./Ref. 1145/53  
Sch./Ref. 1145/54

6

Montare la cornice sul telaio con la chiave fornita a corredo.  
Mount the frame on the panel structure with the provided spanner.  
Monter l'habillage sur le châssis avec la clé livrée avec le produit.  
Poner el marco sobre la armadura con la llave entregada junto al producto.  
Den Einsatz auf den Rahmen mit dem dazu mitgelieferten Schlüssel montieren.

